

---

# HOUSE OF FRASER

## XML PURCHASE ORDER MESSAGE FORMAT

A TECHNICAL GUIDE FOR SUPPLIERS

---

## TABLE OF CONTENTS

1. OVERVIEW .....	3
1.1 Introduction .....	3
2. STRUCTURE .....	4
2.1 XML Document Structure .....	4
2.2 XML Purchase Order Structure .....	4
3. Properties of Elements.....	13
ORDER – Order Details .....	13
3.1 ORDERHEAD – Order Header Details .....	13
3.1.1 ORDERHEAD-CURRENCY – Common Currency Details .....	13
3.2 REFERENCE – Common Reference format.....	14
3.3 DATEINFO – Common Date information .....	14
3.3.1 DATEINFO-DATEINFO – Order Date information.....	14
3.3.2 DATEINFO-DATEINFO – Order-Earliest-Delivery Date information.....	14
3.3.3 DATEINFO-DATEINFO – Order-Latest-Delivery Date information.....	14
3.4 SUPPLIER – Supplier details .....	15
3.4.1 SUPPLIER-PARTYCODE – ‘Supplier Number’ details.....	15
3.4.2 SUPPLIER-ADDRESS – ‘Supplier Address’ details .....	15
3.4.3 SUPPLIER-CONTACT – ‘Contact’ details.....	15
3.5 BUYER – Buyer details .....	16
3.5.1 BUYER-PARTYCODE – ‘Buyer Code’ details.....	16
3.5.2 BUYER-ADDRESS – ‘Buyers Address’ details .....	16
3.5.3 BUYER-CONTACT – ‘Contact’ details .....	16
3.6 DELIVERY – Delivery details.....	17
3.6.1 DELIVERY-PARTYCODE – Delivery Code details .....	17
3.6.2 DELIVERY-ADDRESS – Delivery Address details.....	17
3.6.3 DELIVERY-CONTACT – ‘Contact’ details.....	17
3.6.4 DELIVERY-CARRIER – ‘Carrier’ details .....	18
3.7 INVOICETO – Invoice details .....	19
3.7.1 INVOICETO-PARTYCODE – Invoice details .....	19
3.7.2 INVOICETO-ADDRESS – Address Details.....	19
3.7.3 INVOICETO-CONTACT – ‘Contact’ details.....	20
3.8 ORDERLINE – Order line header.....	20
3.8.1 ORDERLINE-PRODUCT – Ordered-line Codes .....	21
3.8.2 ORDERLINE-QUANTITY.....	22
3.8.3 ORDERLINE-PRICE –Price details .....	22
3.8.4 ORDERLINE-DISCOUNT .....	23
3.8.5 ORDERLINE-DATEINFO.....	23
3.8.6 ORDERLINE-DIMENSION .....	23
3.8.7 ORDERLINE-REFERENCE.....	23
3.8.8 ORDERLINE-DELIVSCHED.....	23
3.8.9 ORDERLINE-NARRATIVE .....	26
3.8.10 ORDERLINE-LINETAX – Order line .....	28
3.9 DISCOUNT – Discount Details .....	28
3.10 NARRATIVE – Common narrative format.....	29
3.10.1 NARRATIVE-NARRATIVE.....	29
3.10.2 NARRATIVE-NARRATIVE.....	29
3.10.3 NARRATIVE-NARRATIVE.....	29
3.10.4 NARRATIVE-NARRATIVE.....	29
3.11 ORDERTOTAL – Order totals .....	29
4. XML PURCHASE ORDERS.....	31
4.1 File Name Conventions .....	31
4.2 XML Declaration.....	31
4.3 Namespace .....	31
4.4 Sample of XML Purchase Orders File .....	31

---

# 1. OVERVIEW

## 1.1 Introduction

This document describes the XML Purchase Order message that House of Fraser offers. You can receive your Purchase Orders in more than one format comprising of XML and EDI. The EDI format we offer is in Edifact and Tradacom and the messages are dispatched via FTP only.

In this document the XML Purchase Order Message format is described and explained to give an understanding of the schema.

Please see the following linked document for list of House of Fraser Ordering Types:

[http://www.hofsuppliers.co.uk/info/pdf/purchase\\_order\\_types.pdf](http://www.hofsuppliers.co.uk/info/pdf/purchase_order_types.pdf)

## 2. STRUCTURE

### 2.1 XML Document Structure

The structure of the XML schema is the same to that of the BASDA standard including the level of hierarchy.

### 2.2 XML Purchase Order Structure

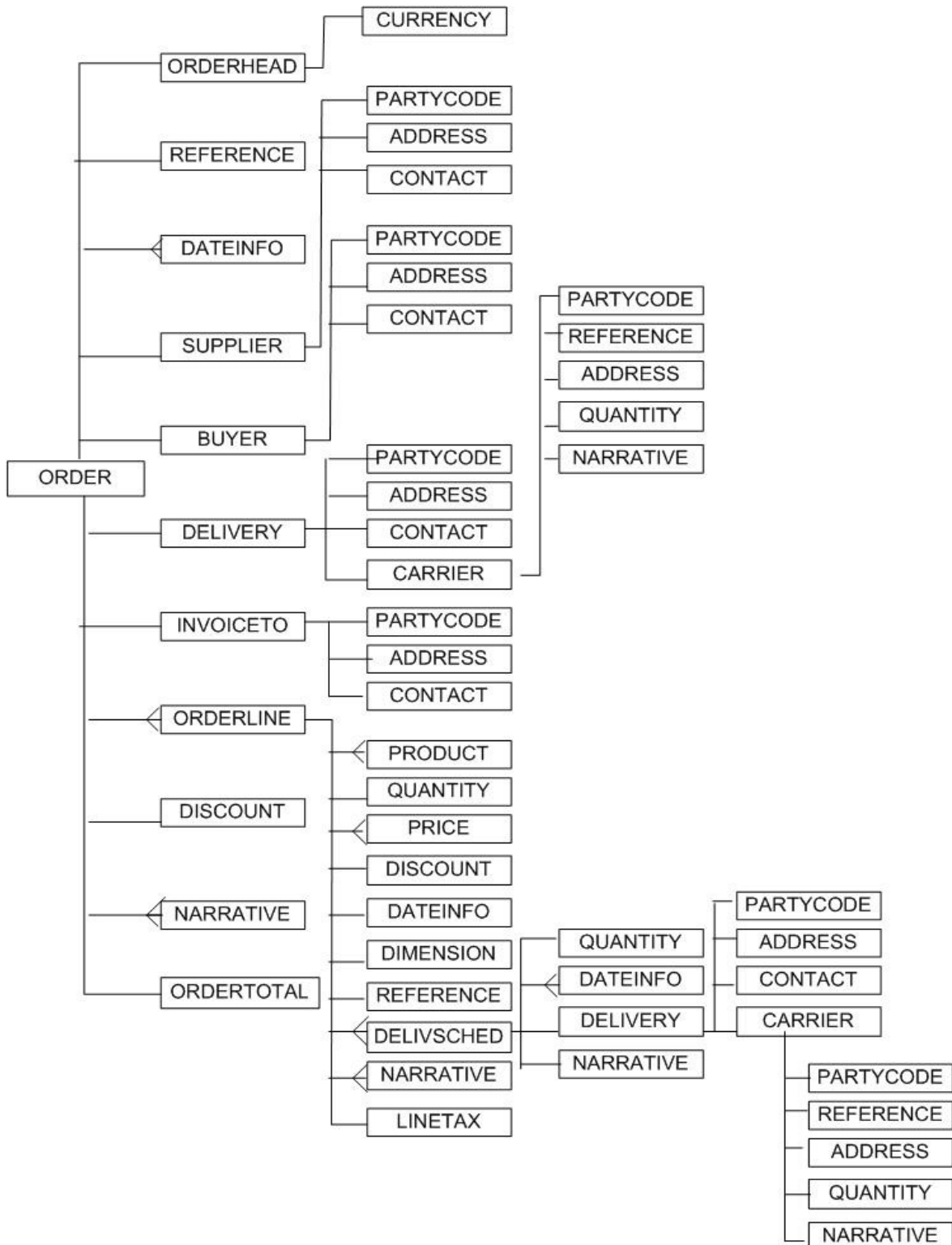

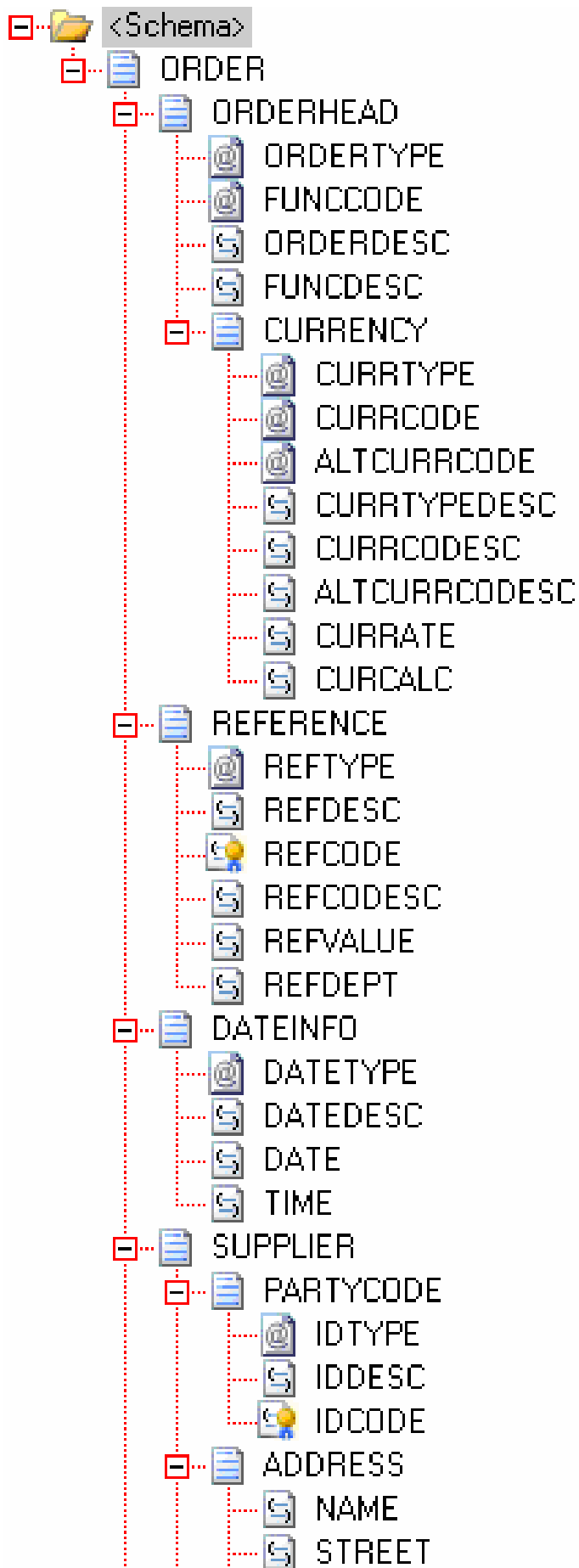

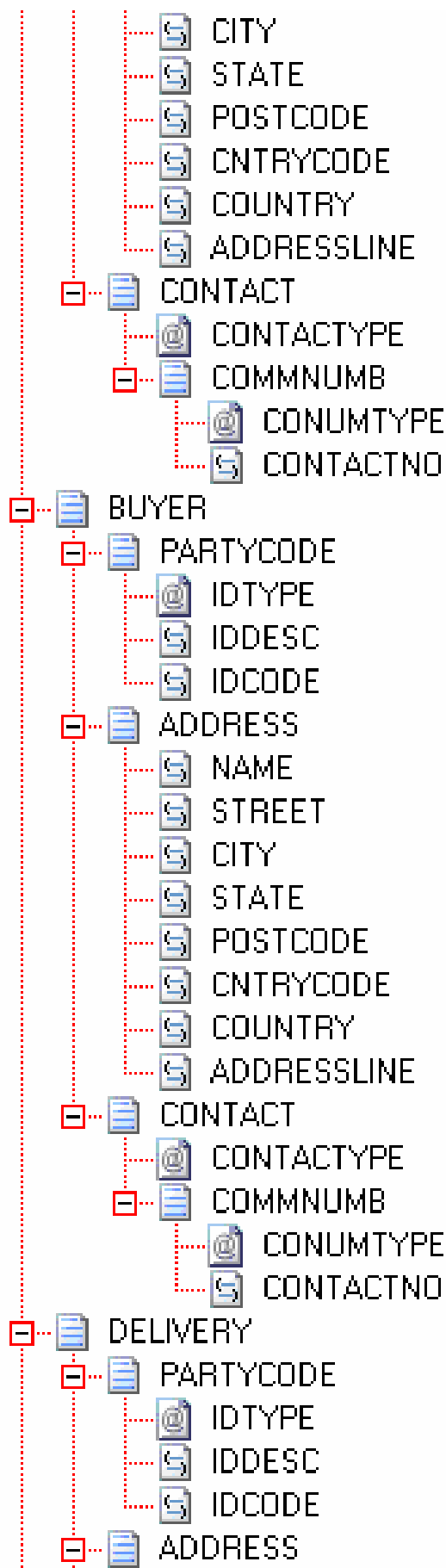

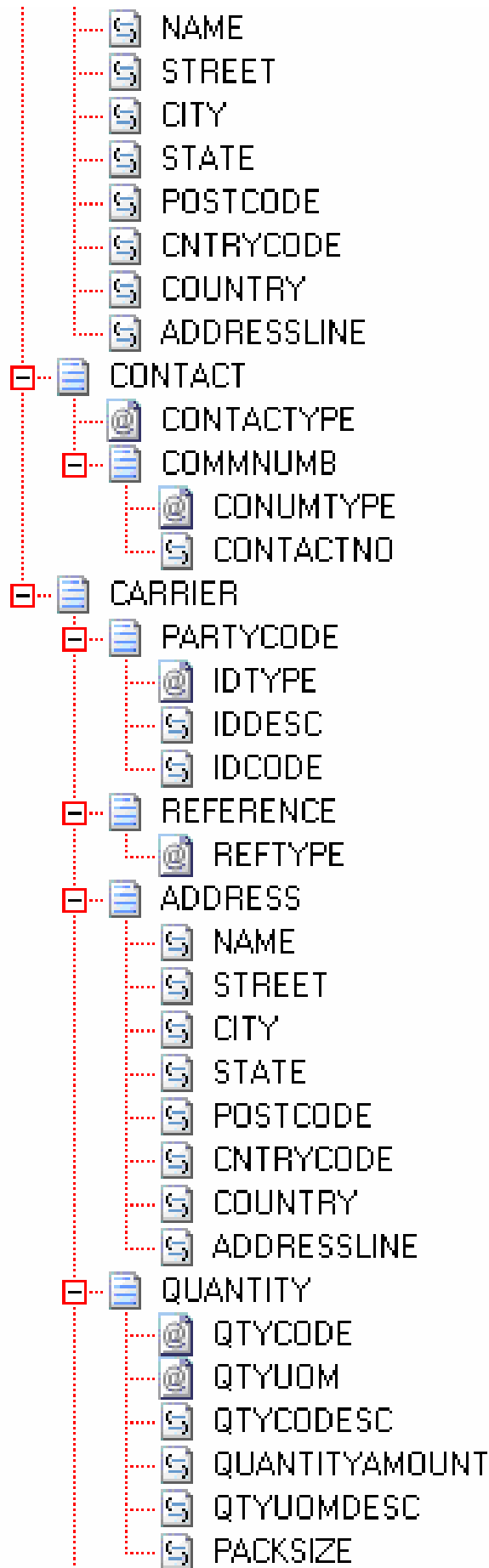

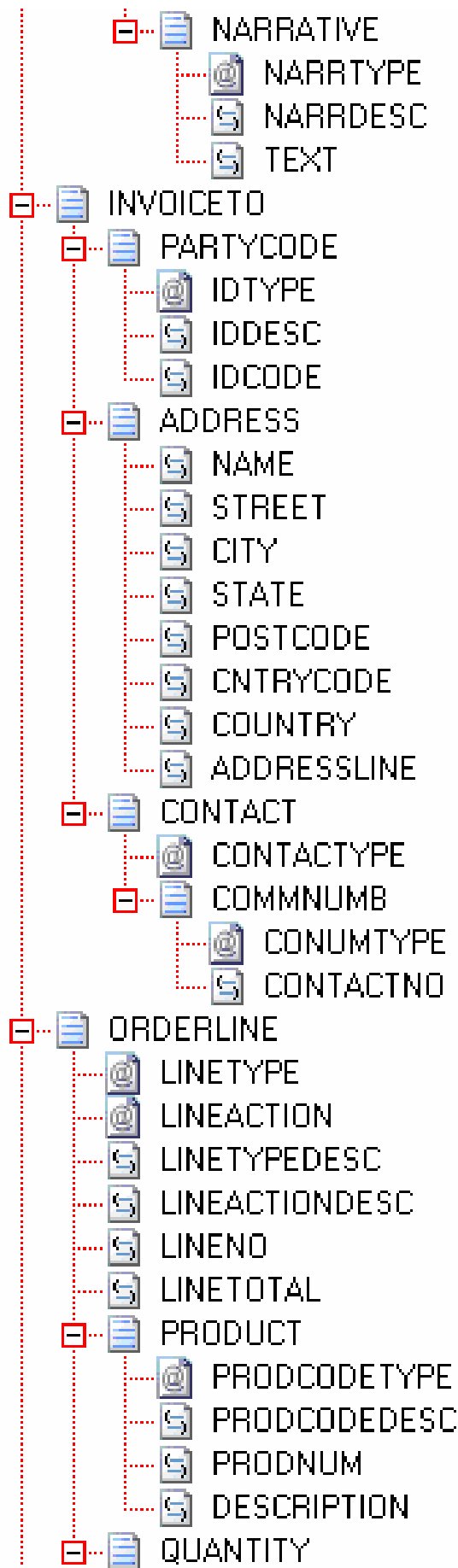



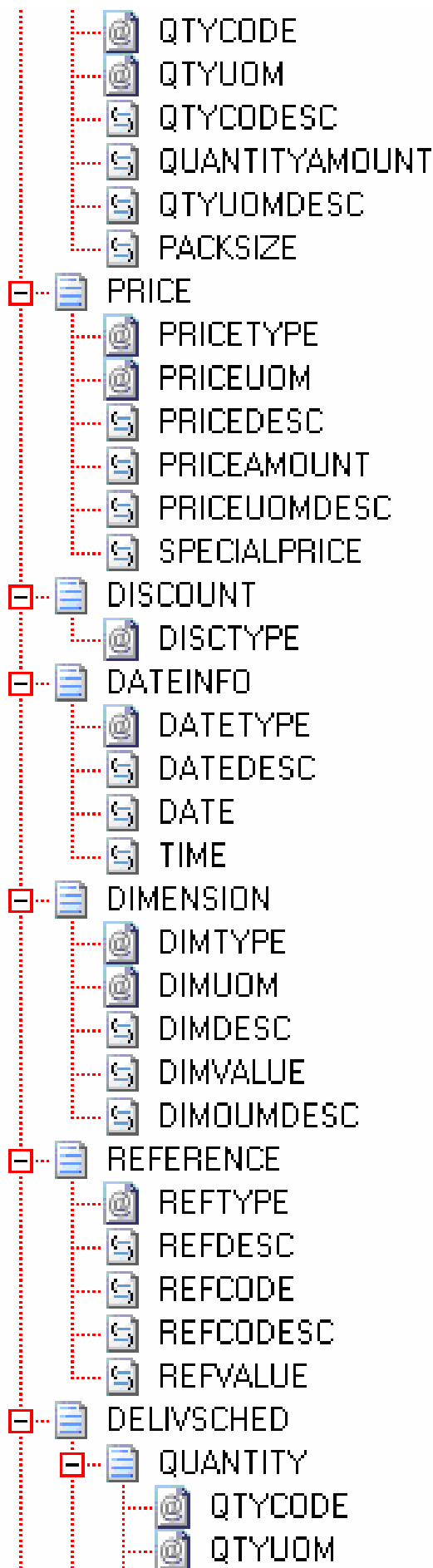

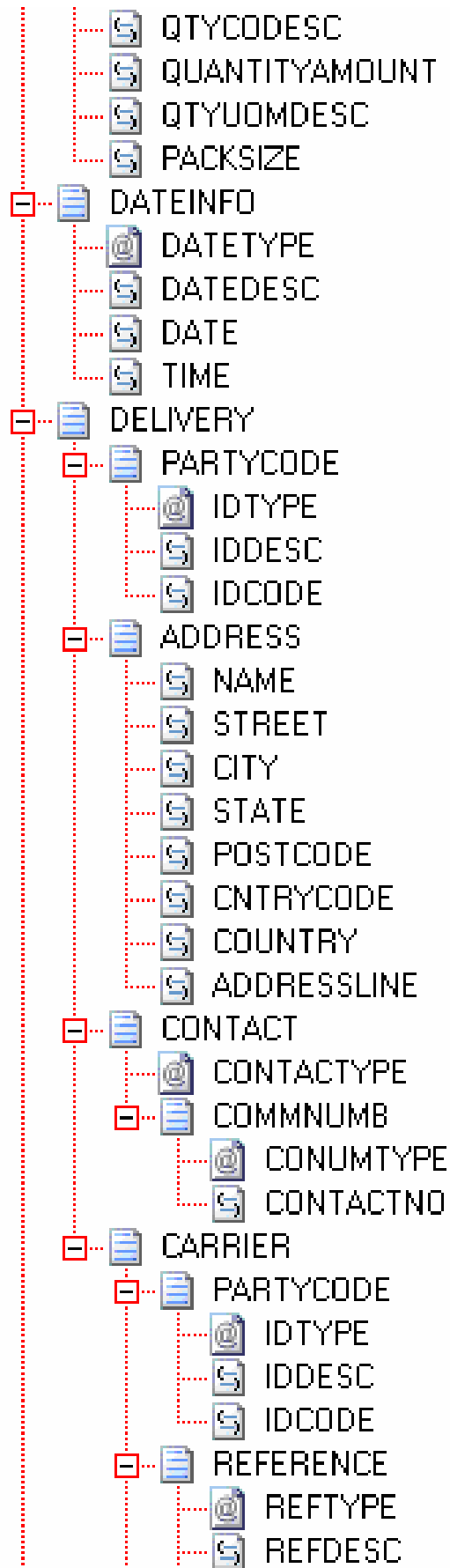

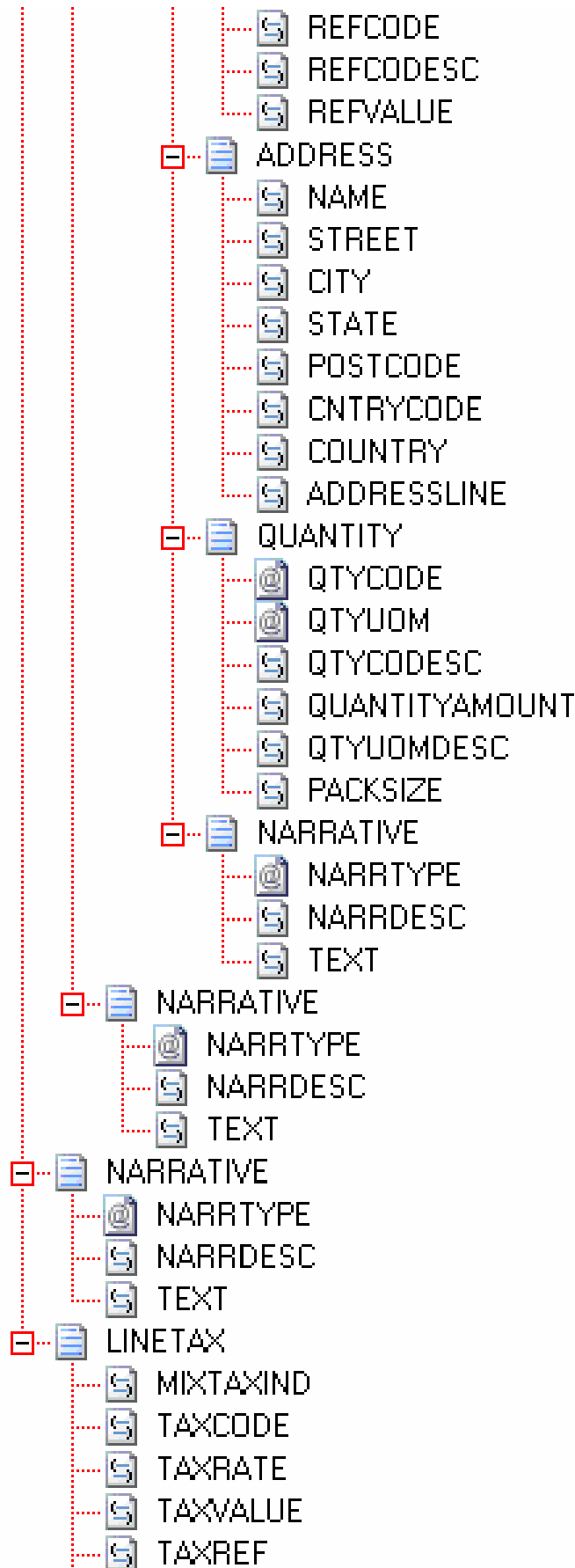

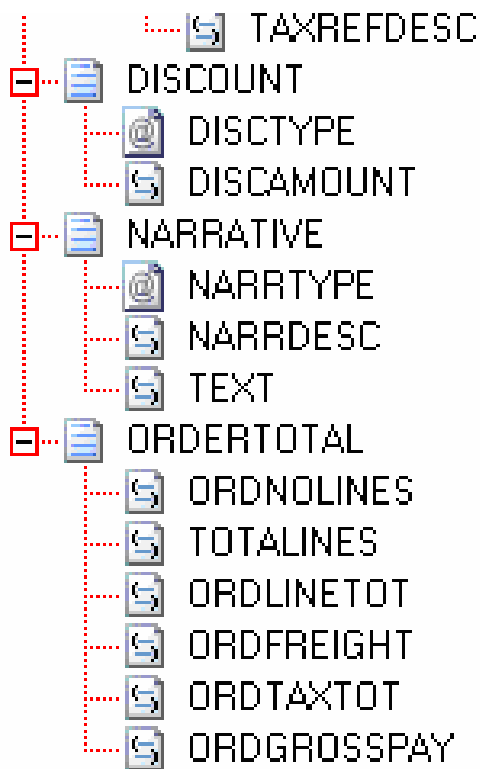

### 3. PROPERTIES OF ELEMENTS

The XML schema should enforce typing for all of the elements. Restrictions on the properties of the elements and the descriptions are shown below in this section.

#### ORDER – Order Details

Node	Element/ Attribute	Required	Description	Pattern
ORDERHEAD	E	Y	See 3.1	
REFERENCE	E	Y	See 3.2	
DATEINFO	E	Y	See 3.3	
SUPPLIER	E	Y	See 3.4	
BUYER	E	Y	See 3.5	
DELIVERY	E	Y	See 3.6	
INVOICETO	E	N	See 3.7	
ORDERLINE	E	Y	See 3.8	
DISCOUNT	E	Y	See 3.9	
NARRATIVE	E	N	See 3.10	
ORDERTOTAL	E	Y	See 3.11	

#### 3.1 ORDERHEAD – Order Header Details

Node	Element/ Attribute	Required	Description	Pattern
ORDERTYPE	A	Y	Order Classification i.e. Set to 'PUO' [code for purchase order]	
FUNCCODE	A	Y	Function Code i.e. Set to 'FIO' [code for Firm order] if the order status = 'New' otherwise ( 'Amend' ) set to 'AMO' [code for Amendment order]	
ORDERDESC	E	Y	Order Classification Description i.e. Set to 'Purchase order'	
FUNCDISC	E	Y	Function Description i.e. Set to 'Firm order' if the order status = 'New' otherwise set to 'Amendment to Existing Order'	
CURRENCY	E	Y	See 3.1.1	

#### 3.1.1 ORDERHEAD-CURRENCY – Common Currency Details

Node	Element/ Attribute	Required	Description	Pattern
CURRTYPE	A	Y	Currency Type code i.e. Set to 'ORD'	
CURRCODE	A	Y	Base Currency Code i.e. Set to 'GBP'	
ALTCURRCODE	A	N	Alternate Currency Code	
CURRTYPEDESC	E	Y	Currency Type Description i.e. Set to 'Order Currency'	
CURRCODEDESC	E	Y	Base Currency Code Description i.e. Set to 'Pound Sterling'	
ALTCURRCODEDESC	E	N	Alternate Currency Code Description	
CURRATE	E	N	Currency Rate i.e. Set to '0.0' or omit, as not mandatory	
CURCALC	E	N	Method of currency calculation	

### 3.2 REFERENCE – Common Reference format

Node	Element/ Attribute	Required	Description	Pattern
REFTYPE	A	Y	Reference Type i.e. Set to 'CUR' *	
REFDESC	E	N	Description of reference i.e. Set to 'Customers Purchase Order Number'	
REFCODE	E	Y	Reference Code i.e. Purchase order number	
REFCODEDESC	E	N	Reference Code Description i.e. Description of purchase order number	
REFVALUE	E	Y	Reference Value i.e. Order type e.g. 'CMS', 'PO5', 'PO6'	
REFDEPT	E	Y	Reference Department Code e.g. 0974	[0-9]{4} - Any numbers with a length of 4 digits

\*Could also have REFTYPE = 'ACR' (Alternative Customer Reference) or 'CCN' (Customer's Name)

### 3.3 DATEINFO – Common Date information

Node	Element/ Attribute	Required	Description	Pattern
DATEINFO	E	Y	See 3.3.1	
DATEINFO	E	N	See 3.3.2	
DATEINFO	E	N	See 3.3.3	

#### 3.3.1 DATEINFO-DATEINFO – Order Date information

Mandatory purchase order date information, for 'order date'

Node	Element/ Attribute	Required	Description	Pattern
DATETYPE	A	Y	Date Type i.e. Set to 'ORD'	
DATEDESC	E	Y	Description of date i.e. Set to 'Purchase Order Date'	
DATE	E	Y	Date E.g. 2002-02-19	
TIME	E	N	Time E.g. 10:50:22:84	

#### 3.3.2 DATEINFO-DATEINFO – Order-Earliest-Delivery Date information

Additional purchase order date information, for 'expected date'

Node	Element/ Attribute	Required	Description	Pattern
DATETYPE	A	Y	Date Type i.e. Set to 'EDD'	
DATEDESC	E	Y	Description of date i.e. Set to 'Earliest Delivery Date'	
DATE	E	Y	Date E.g. 2002-02-19	
TIME	E	N	Time E.g. 10:50:22:84	

#### 3.3.3 DATEINFO-DATEINFO – Order-Latest-Delivery Date information

Additional purchase order date information, for 'completion date'

Node	Element/ Attribute	Required	Description	Pattern
DATETYPE	A	Y	Date Type	

Node	Element/ Attribute	Required	Description	Pattern
			i.e. Set to 'LDD'	
DATEDESC	E	Y	Description of date i.e. Set to 'Latest Delivery Date'	
DATE	E	Y	Date E.g. 2002-02-19	
TIME	E	N	Time E.g. 10:50:22:84	

### 3.4 SUPPLIER – Supplier details

Node	Element/ Attribute	Required	Description	Pattern
PARTYCODE	E	Y	See 3.4.1	
ADDRESS	E	N	See 3.4.2	
CONTACT	E	Y	See 3.4.3	

#### 3.4.1 SUPPLIER-PARTYCODE – ‘Supplier Number’ details

Node	Element/ Attribute	Required	Description	Pattern
IDTYPE	A	Y	Identification code type i.e. Set to 'BCS'	
IDDESC	E	Y	Description of code i.e. Set to 'Buyers Code for Supplier'	
IDCODE	E	Y	Identification code e.g. '5029839'	

#### 3.4.2 SUPPLIER-ADDRESS – ‘Supplier Address’ details

Node	Element/ Attribute	Required	Description	Pattern
NAME	E	Y	Address name e.g. Test Supplier	
STREET	E	N	Street e.g. Faraday Road	
CITY	E	N	City e.g. Swindon	
STATE	E	N	State/ county/ province e.g. Wiltshire	
POSTCODE	E	N	Post/ ZIP code e.g. SN3 3HS	
CNTRYCODE	E	N	Country code e.g. UK	
COUNTRY	E	N	Country e.g. England	
ADDRESSLINE	E	N	Address lines – free format	

#### 3.4.3 SUPPLIER-CONTACT – ‘Contact’ details

Node	Element/ Attribute	Required	Description	Pattern
CONTACTYPE	A	Y	Not used by HoF but still outputted. E.g. “ ”	
COMMNUMB	E	N	See 3.4.3.1	

**3.4.3.1 SUPPLIER-CONTACT-COMMNUMB -**

Node	Element/ Attribute	Required	Description	Pattern
CONUMTYPE	A	Y	Not used by HoF but still outputted. E.g. “ ”	
CONTACTNO	E	N	Not used by HoF	

**3.5 BUYER – Buyer details**

Node	Element/ Attribute	Required	Description	Pattern
PARTYCODE	E	Y	See 3.5.1	
ADDRESS	E	Y	See 3.5.2	
CONTACT	E	N	See 3.5.3	

**3.5.1 BUYER-PARTYCODE – ‘Buyer Code’ details**

Node	Element/ Attribute	Required	Description	Pattern
IDTYPE	A	Y	Identification code i.e. Set to ‘SCB’	
IDDESC	E	Y	Description of code i.e. Set to ‘Suppliers Code for Buyer’	
IDCODE	E	Y	Identification code i.e. Set to ‘5019589000016’ for central orders	

**3.5.2 BUYER-ADDRESS – ‘Buyers Address’ details**

Node	Element/ Attribute	Required	Description	Pattern
NAME	E	Y	Address name e.g. Kendals	
STREET	E	N	Street e.g. PO Box 60, Deansgate	
CITY	E	N	City e.g. Manchester	
STATE	E	N	State/ county/ province e.g. Lancashire	
POSTCODE	E	N	Post/ ZIP code e.g. M60 3AU	
CNTRYCODE	E	N	Country code e.g. UK	
COUNTRY	E	N	Country e.g. England	
ADDRESSLINE	E	N	Address lines – free format	

**3.5.3 BUYER-CONTACT – ‘Contact’ details**

Node	Element/ Attribute	Required	Description	Pattern
CONTACTTYPE	A	Y	Not used by HoF but still outputted. E.g. “ ”	
COMMNUMB	E	N	Not used by HoF	



**3.5.3.1 BUYER-CONTACT-COMMNUMB – Contact number details**

Node	Element/ Attribute	Required	Description	Pattern
CONUMTYPE	A	Y	Not used by HoF but still outputted. E.g. “ ”	
CONTACTNO	E	Y	Not used by HoF	

**3.6 DELIVERY – Delivery details**

Node	Element/ Attribute	Required	Description	Pattern
PARTYCODE	E	Y	See 3.6.1	
ADDRESS	E	N	See 3.6.2	
CONTACT	E	N	See 3.6.3	
CARRIER	E	Y	See 3.6.4	

**3.6.1 DELIVERY-PARTYCODE – Delivery Code details**

Node	Element/ Attribute	Required	Description	Pattern
IDTYPE	A	Y	Identification code type i.e. Set to ‘DEL’	
IDDESC	E	Y	Description of code i.e. Set to ‘Deliver To’	
IDCODE	E	Y	Identification code i.e. Store number	

**3.6.2 DELIVERY-ADDRESS – Delivery Address details**

ONLY REQUIRED FOR CSM ORDERS WHERE CUSTOMER DETAILS ARE PASSED TO EDI AS PART OF THE DELIVERY ADDRESS

Node	Element/ Attribute	Required	Description	Pattern
NAME	E	Y	Address name - Only populated if store order or delivery to customer. e.g. Mrs K Scott	
STREET	E	N	Street - Only populated if store order or delivery to customer. e.g. Moss Hall Road	
CITY	E	N	City - Only populated if store order or delivery to customer. e.g. Bury	
STATE	E	N	State/ County/ Province - Only populated if store order or delivery to customer. e.g. Lancashire	
POSTCODE	E	N	Post/ ZIP code - Only populated if store order or delivery to customer. e.g. BL9 7JJ	
CNTRYCODE	E	N	Country code e.g. UK	
COUNTRY	E	N	Country e.g. England	
ADDRESSLINE	E	N	Address lines – free format	

**3.6.3 DELIVERY-CONTACT – ‘Contact’ details**

Node	Element/ Attribute	Required	Description	Pattern
CONTACTYPE	A	Y	Not used by HoF but still outputted. E.g. “ ”	
COMMNUMB	E	N	See 3.6.3.1	

### 3.6.3.1 DELIVERY-CONTACT-COMMNUMB – Contact Number Details

Node	Element/ Attribute	Required	Description	Pattern
CONUMTYPE	A	Y	Not used by HoF but still outputted. E.g. “ ”	
CONTACTNO	E	Y	Not used by HoF	

### 3.6.4 DELIVERY-CARRIER – ‘Carrier’ details

Node	Element/ Attribute	Required	Description	Pattern
PARTYCODE	E	Y	See 3.6.4.1	
REFERENCE	E	N	See 3.6.4.2	
ADDRESS	E	N	See 3.6.4.3	
QUANTITY	E	N	See 3.6.4.4	
NARRATIVE	E	N	See 3.6.4.5	

#### 3.6.4.1 DELIVERY-CARRIER-PARTYCODE – Carrier Code Details

Node	Element/ Attribute	Required	Description	Pattern
IDTYPE	A	Y	Identification code type	
IDDESC	E	N	Description of code	
IDCODE	E	Y	Identification code	

#### 3.6.4.2 DELIVERY-CARRIER-REFERENCE – Reference Detail

Node	Element/ Attribute	Required	Description	Pattern
REFTYPE	A	Y	Reference Type i.e. Set to ‘ART’	

#### 3.6.4.3 DELIVERY-CARRIER-ADDRESS – Address Details

Node	Element/ Attribute	Required	Description	Pattern
NAME	E	N	Address name e.g. Test Supplier	
STREET	E	N	Street e.g. Faraday Road	
CITY	E	N	City e.g. Swindon	
STATE	E	N	State/ county/ province e.g. Wiltshire	
POSTCODE	E	N	Post/ ZIP code e.g. SN3 3HS	
CNTRYCODE	E	N	Country code e.g. UK	

Node	Element/ Attribute	Required	Description	Pattern
COUNTRY	E	N	Country e.g. England	
ADDRESSLINE	E	N	Address lines – free format	

### 3.6.4.4 DELIVERY-CARRIER-QUANTITY – Quantity Detail

Node	Element/ Attribute	Required	Description	Pattern
QTYCODE	A	N	Quantity code i.e. Set to 'ORD' or null, as not mandatory	
QTYUOM	A	N	Unit of measure code i.e. Set to 'PCE' or null, as not mandatory	
QTYCODESC	E	N	Quantity code description i.e. Set to 'Ordered Quantity'	
QUANTITYAMOUNT	E	N	Quantity – amount	
QTYUOMDESC	E	N	Unit of measure description i.e. Set to 'Pieces' or omit, as not mandatory	
PACKSIZE	E	N	Number of units in the pack	

### 3.6.4.5 DELIVERY-CARRIER-NARRATIVE -

Node	Element/ Attribute	Required	Description	Pattern
NARRTYPE	A	Y	Narrative type i.e. Set to GNAR1	
NARRDESC	E	N	Description of narrative	
TEXT	E	N	Narrative text	

## 3.7 INVOICETO – Invoice details

Node	Element/ Attribute	Required	Description	Pattern
PARTYCODE	E	Y	See 3.7.1	
ADDRESS	E	N	See 3.7.2	
CONTACT	E	N	See 3.7.3	

### 3.7.1 INVOICETO-PARTYCODE – Invoice details

Node	Element/ Attribute	Required	Description	Pattern
IDTYPE	A	Y	Identification code type i.e. Set to 'INV'	
IDDESC	E	N	Description of code i.e. Set to 'Invoice To'	
IDCODE	E	Y	Identification code i.e. Set to '5019589000016'	

### 3.7.2 INVOICETO-ADDRESS – Address Details

Node	Element/ Attribute	Required	Description	Pattern
NAME	E	N	Address name e.g. Kendals	
STREET	E	N	Street e.g. PO Box 60, Deansgate	
CITY	E	N	City e.g. Manchester	
STATE	E	N	State/ county/ province e.g. Lancashire	
POSTCODE	E	N	Post/ ZIP code e.g. M60 3AU	
CNTRYCODE	E	N	Country code e.g. UK	
COUNTRY	E	N	Country e.g. England	
ADDRESSLINE	E	N	Address lines – free format	

### 3.7.3 INVOICETO-CONTACT – ‘Contact’ details

Node	Element/ Attribute	Required	Description	Pattern
CONTACTYPE	A	Y	Not used by HoF but still outputted. E.g. “ ”	
COMMNUMB	E	N	See 3.7.3.1	

#### 3.7.3.1 INVOICETO -CONTACT-COMMNUMB – Contact Number Details

Node	Element/ Attribute	Required	Description	Pattern
CONUMTYPE	A	Y	Not used by HoF but still outputted. E.g. “ ”	
CONTACTNO	E	Y	Not used by HoF	

### 3.8 ORDERLINE – Order line header

Node	Element/ Attribute	Required	Description	Pattern
LINETYPE	A	Y	Order line type i.e. Set to ‘GDS’	
LINEACTION	A	Y	Order line action code i.e. Set to ‘1’ for each unprocessed entry where the order status = ‘New’, else set to ‘3’ for order status = ‘Amend’	
LINETYPEDESC	E	Y	Order line type description i.e. Set to ‘Goods’	
LINEACTIONDESC	E	Y	Order line action description i.e. If LINEACTION = ‘1’ set to ‘Add Line’, else if LINEACTION = ‘3’ set to ‘Change Line’	
LINENO	E	Y	Order Line Number	
LINETOTAL	E	Y	Extended line value	
PRODUCT	E	Y	See 3.8.1	
QUANTITY	E	Y	See 3.8.2	
PRICE	E	Y	See 3.8.3	
DISCOUNT	E	N	See 3.8.4	
DATEINFO	E	Y	See 3.8.5	
DIMENSION	E	Y	See 3.8.6	
REFERENCE	E	N	See 3.8.7	
DELIVSCHED	E	Y	See 3.8.8	

Node	Element/ Attribute	Required	Description	Pattern
NARRATIVE	E	N	See 3.8.9	
LINETAX	E	Y	See 3.8.10	

### 3.8.1 ORDERLINE-PRODUCT – Ordered-line Codes

Node	Element/ Attribute	Required	Description	Pattern
PRODUCT	E	Y	See 3.8.1.1	
PRODUCT	E	N	See 3.8.1.2	
PRODUCT	E	N	See 3.8.1.3	
PRODUCT	E	N	See 3.8.1.4	

#### 3.8.1.1 ORDERLINE-PRODUCT – Ordered line

Product detail information, for 'sellers product codes'

Node	Element/ Attribute	Required	Description	Pattern
PRODCODETYPE	A	Y	Product reference type i.e. Set to 'SPC'	
PRODCODEDESC	E	Y	Product code description i.e. Set to 'Sellers Product Code'	
PRODNUM	E	Y	Product reference number e.g. CHIC1	
DESCRIPTION	E	Y	Product description	

#### 3.8.1.2 ORDERLINE-PRODUCT – Ordered lines

Node	Element/ Attribute	Required	Description	Pattern
PRODCODETYPE	A	Y	Product reference type i.e. Set to 'BPC'	
PRODCODEDESC	E	Y	Product code description i.e. Set to 'Buyers Part'	
PRODNUM	E	Y	Product reference number	
DESCRIPTION	E	Y	Product description	

#### 3.8.1.3 ORDERLINE- PRODUCT – Ordered lines

Node	Element/ Attribute	Required	Description	Pattern
PRODCODETYPE	A	Y	Product reference type i.e. Set to 'ANA'	
PRODCODEDESC	E	Y	Product code description i.e. Set to 'Sellers EAN13'	
PRODNUM	E	Y	Product reference number	
DESCRIPTION	E	Y	Product description	

#### 3.8.1.4 ORDERLINE-PRODUCT – Ordered lines

Node	Element/ Attribute	Required	Description	Pattern
PRODCODETYPE	A	Y	Product code type i.e. Set to 'USR'	
PRODCODEDESC	E	Y	Product code description – Hof product code	

Node	Element/Attribute	Required	Description	Pattern
			i.e. Set to 'HOFEAN13'	
PRODNUM	E	Y	Product reference number	
DESCRIPTION	E	Y	Product description	

### 3.8.2 ORDERLINE-QUANTITY

Node	Element/Attribute	Required	Description	Pattern
QTYCODE	A	N	Quantity code i.e. Set to 'ORD' or null, as not mandatory	
QTYUOM	A	N	Unit of measure code i.e. Set to 'PCE' or null, as not mandatory	
QTYCODESC	E	N	Quantity code description i.e. Set to 'Ordered Quantity'	
QUANTITYAMOUNT	E	Y	Quantity – amount	[0-9]{1,9} Any numbers with a length of 1 to 9 digits
QTYUOMDESC	E	N	Unit of measure description i.e. Set to 'Pieces' or omit, as not mandatory	
PACKSIZE	E	N	Number of units in the pack	

### 3.8.3 ORDERLINE-PRICE –Price details

Node	Element/Attribute	Required	Description	Pattern
PRICE	E	Y	See 3.8.3.1	
PRICE	E	Y	See 3.8.3.2	

#### 3.8.3.1 ORDERLINE-PRICE – Cost price details

Node	Element/Attribute	Required	Description	Pattern
PRICETYPE	A	Y	Price type code i.e. Set to 'COS'	
PRICEUOM	A	Y	Pricing unit of measure i.e. Set to 'PCE'	
PRICEDESC	E	Y	Description of price i.e. Set to 'Cost'	
PRICEAMOUNT	E	Y	Price (amount)	
PRICEUOMDESC	E	Y	Price unit of measure description i.e. Set to 'Piece'	
SPECIALPRICE	E	N	Special price indicator	

All prices to be shown in £s & pence to 2 decimal places with a decimal point.

#### 3.8.3.2 ORDERLINE-PRICE– Selling price details

Node	Element/Attribute	Required	Description	Pattern
PRICETYPE	A	Y	Price type code i.e. Set to 'RRP'	
PRICEUOM	A	Y	Pricing unit of measure i.e. Set to 'PCE'	
PRICEDESC	E	Y	Description of price	

Node	Element/ Attribute	Required	Description	Pattern
			i.e. Set to 'Selling'	
PRICEAMOUNT	E	Y	Price (amount)	
PRICEUMDESC	E	Y	Price unit of measure description i.e. Set to 'Piece'	
SPECIALPRICE	E	N	Special price indicator	

All prices to be shown in £s & pence to 2 decimal places with a decimal point.

### 3.8.4 ORDERLINE-DISCOUNT

Node	Element/ Attribute	Required	Description	Pattern
DISCTYPE	A	N	Discount type	

### 3.8.5 ORDERLINE-DATEINFO

Node	Element/ Attribute	Required	Description	Pattern
DATETYPE	A	Y	Date Type	
DATEDESC	E	N	Description of date	
DATE	E	Y	Date E.g. 2005-05-19	
TIME	E	N	Time E.g. 10:50:22:84	

### 3.8.6 ORDERLINE-DIMENSION

Node	Element/ Attribute	Required	Description	Pattern
DIMTYPE	A	N	Dimension type (code)	
DIMUOM	A	N	Unit of measure	
DIMDESC	E	N	Description of dimension	
DIMVALUE	E	N	Dimension E.g. 0.0	
DIMUOMDESC	E	N	Dimension unit of measure description	

### 3.8.7 ORDERLINE-REFERENCE

Node	Element/ Attribute	Required	Description	Pattern
REFTYPE	A	Y	Reference Type i.e. Set to 'ART'	
REFDESC	E	N	Description of reference	
REFCODE	E	N	Reference Code	
REFCODEDESC	E	N	Reference Code Description	
REFVALUE	E	N	Reference Value	

### 3.8.8 ORDERLINE-DELIVSCHED

Node	Element/ Attribute	Required	Description	Pattern
QUANTITY	E	N	See 3.8.8.1	
DATEINFO	E	Y	See 3.8.8.2	
DELIVERY	E	Y	See 3.8.8.3	
NARRATIVE	E	N	See 3.8.8.3.10	

**3.8.8.1 ORDERLINE-DELIVSCHED-QUANTITY**

Node	Element/ Attribute	Required	Description	Pattern
QTYCODE	A	N	Quantity code i.e. Set to 'ORD' or null, as not mandatory	
QTYUOM	A	N	Unit of measure code i.e. Set to 'PCE' or null, as not mandatory	
QTYCODESC	E	N	Quantity code description i.e. Set to 'Ordered Quantity'	
QUANTITYAMOUNT	E	N	Quantity – amount	
QTYUOMDESC	E	N	Unit of measure description i.e. Set to 'Pieces' or omit, as not mandatory	
PACKSIZE	E	N	Number of units in the pack	

**3.8.8.2 ORDERLINE-DELIVSCHED-DATEINFO**

Node	Element/ Attribute	Required	Description	Pattern
DATETYPE	A	Y	i.e. Set to 'DED'	
DATEDESC	E	N	i.e. Set to 'Required Delivery Date'	
DATE	E	Y	Date E.g. 2002-02-19	
TIME	E	N	Time E.g. 10:50:22:84	

**3.8.8.3 ORDERLINE-DELIVSCHED-DELIVERY**

Node	Element/ Attribute	Required	Description	Pattern
PARTYCODE	E	N	See 3.8.8.3.1	
ADDRESS	E	N	See 3.8.8.3.2	
CONTACT	E	N	See 3.8.8.3.3	
CARRIER	E	Y	See 3.8.8.3.5	

**3.8.8.3.1 ORDERLINE-DELIVSCHED-DELIVERY-PARTYCODE**

Node	Element/ Attribute	Required	Description	Pattern
IDTYPE	A	N	Identification code type	
IDDESC	E	N	Description of code	
IDCODE	E	N	Identification code	

**3.8.8.3.2 ORDERLINE-DELIVSCHED-DELIVERY-ADDRESS – Address Details**

Node	Element/ Attribute	Required	Description	Pattern
NAME	E	N	Address name e.g. Kendals	
STREET	E	N	Street e.g. PO Box 60, Deansgate	
CITY	E	N	City e.g. Manchester	
STATE	E	N	State/ county/ province e.g. Lancashire	
POSTCODE	E	N	Post/ ZIP code e.g. M60 3AU	
CNTRYCODE	E	N	Country code e.g. UK	
COUNTRY	E	N	Country	



Node	Element/ Attribute	Required	Description	Pattern
			e.g. England	
ADDRESSLINE	E	N	Address lines – free format	

### 3.8.8.3.3 ORDERLINE-DELIVSCHED-DELIVERY-CONTACT – Contact Number Details

Node	Element/ Attribute	Required	Description	Pattern
CONTACTYPE	A	Y	Not used by HoF but still outputted. E.g. “ ”	
COMMNUMB	E	Y	See 3.8.8.3.4	

### 3.8.8.3.4 ORDERLINE-DELIVSCHED-DELIVERY-CONTACT-COMMNUMB

Node	Element/ Attribute	Required	Description	Pattern
CONUMTYPE	A	Y	Not used by HoF but still outputted. E.g. “ ”	
CONTACTNO	E	Y	Not used by HoF	

### 3.8.8.3.5 ORDERLINE-DELIVSCHED-DELIVERY-CARRIER – ‘Carrier’ details

Node	Element/ Attribute	Required	Description	Pattern
PARTYCODE	E	N	See 3.8.8.3.6	
REFERENCE	E	Y	See 3.8.8.3.7	
ADDRESS	E	N	See 3.8.8.3.8	
QUANTITY	E	Y	See 3.8.8.3.9	
NARRATIVE	E	Y	See 3.8.8.3.10	

### 3.8.8.3.6 ORDERLINE-DELIVSCHED-DELIVERY-CARRIER-PARTYCODE

Node	Element/ Attribute	Required	Description	Pattern
IDTYPE	A	Y	Identification code type	
IDDESC	E	N	Description of code	
IDCODE	E	N	Identification code	

### 3.8.8.3.7 ORDERLINE-DELIVSCHED-DELIVERY-CARRIER-REFERENCE – Reference Detail

Node	Element/ Attribute	Required	Description	Pattern
REFTYPE	A	Y	Reference Type i.e. Set to ‘ART’	
REFDESC	E	N	Description of reference	
REFCODE	E	N	Reference Code	
REFCODESC	E	N	Reference Code Description	
REFVALUE	E	N	Reference Value	

### 3.8.8.3.8 ORDERLINE-DELIVSCHED-DELIVERY-CARRIER-ADDRESS – Address Details

Node	Element/ Attribute	Required	Description	Pattern
------	-----------------------	----------	-------------	---------

Node	Element/ Attribute	Required	Description	Pattern
NAME	E	N	Address name e.g. Test Supplier	
STREET	E	N	Street e.g. Faraday Road	
CITY	E	N	City e.g. Swindon	
STATE	E	N	State/ county/ province e.g. Wiltshire	
POSTCODE	E	N	Post/ ZIP code e.g. SN3 3HS	
CNTRYCODE	E	N	Country code e.g. UK	
COUNTRY	E	N	Country e.g. England	
ADDRESSLINE	E	N	Address lines – free format	

### 3.8.8.3.9 ORDERLINE-DELIVSCHED-DELIVERY-CARRIER-QUANTITY – Quantity Detail

Node	Element/ Attribute	Required	Description	Pattern
QTYCODE	A	N	Quantity code i.e. Set to 'ORD' or null, as not mandatory	
QTYUOM	A	N	Unit of measure code i.e. Set to 'PCE' or null, as not mandatory	
QTYCODESC	E	N	Quantity code description i.e. Set to 'Ordered Quantity'	
QUANTITYAMOUNT	E	N	Quantity – amount	
QTYUOMDESC	E	N	Unit of measure description i.e. Set to 'Pieces' or omit, as not mandatory	
PACKSIZE	E	N	Number of units in the pack	

### 3.8.8.3.10 ORDERLINE-DELIVSCHED-DELIVERY-CARRIER-NARRATIVE

Node	Element/ Attribute	Required	Description	Pattern
NARRTYPE	A	Y	Narrative type i.e. Set to GNAR1	
NARRDESC	E	N	Description of narrative	
TEXT	E	N	Narrative text	

### 3.8.9 ORDERLINE-NARRATIVE

Node	Element/ Attribute	Required	Description	Pattern
NARRATIVE	E	N	See 3.8.9.1	
NARRATIVE	E	N	See 3.8.9.2	
NARRATIVE	E	N	See 3.8.9.3	
NARRATIVE	E	N	See 3.8.9.4	
NARRATIVE	E	N	See 3.8.9.5	
NARRATIVE	E	N	See 3.8.9.6	
NARRATIVE	E	N	See 3.8.9.7	
NARRATIVE	E	N	See 3.8.9.8	
NARRATIVE	E	N	See 3.8.9.9	

**3.8.9.1 ORDERLINE-NARRATIVE**

Using for General narrative 1-4

Node	Element/ Attribute	Required	Description	Pattern
NARRTYPE	A	Y	Narrative type i.e. Set to GNAR1	
NARRDESC	E	N	Description of narrative	
TEXT	E	N	Narrative text	

**3.8.9.2 ORDERLINE-NARRATIVE**

Using for General narrative 1-4

Node	Element/ Attribute	Required	Description	Pattern
NARRTYPE	A	Y	Narrative type i.e. Set to GNAR2	
NARRDESC	E	N	Description of narrative	
TEXT	E	N	Narrative text	

**3.8.9.3 ORDERLINE-NARRATIVE**

Using for General narrative 1-4

Node	Element/ Attribute	Required	Description	Pattern
NARRTYPE	A	Y	Narrative type i.e. Set to GNAR3	
NARRDESC	E	N	Description of narrative	
TEXT	E	N	Narrative text	

**3.8.9.4 ORDERLINE-NARRATIVE**

Using for General narrative 1-4

Node	Element/ Attribute	Required	Description	Pattern
NARRTYPE	A	Y	Narrative type i.e. Set to GNAR4	
NARRDESC	E	N	Description of narrative	
TEXT	E	N	Narrative text	

**3.8.9.5 ORDERLINE-NARRATIVE**

Using for Ticketing: 249 – Ticket Type (eg. ‘W’ – Swing, ‘L’ – Large Adhesive, ‘S’ – Small Adhesive, ‘D’ – Dumbbell)

Node	Element/ Attribute	Required	Description	Pattern
NARRTYPE	A	Y	Narrative type i.e. Set to ‘249’	
NARRDESC	E	N	Description of narrative i.e. Set to ‘Ticket type’	
TEXT	E	N	Narrative text	

**3.8.9.6 ORDERLINE-NARRATIVE**

Using for Ticketing: 141 – Colour

Node	Element/ Attribute	Required	Description	Pattern
NARRTYPE	A	Y	Narrative type i.e. Set to ‘141’	
NARRDESC	E	N	Description of narrative i.e. Set to ‘Colour’	
TEXT	E	N	Narrative text	

### 3.8.9.7 ORDERLINE-NARRATIVE

Using for Ticketing: 142 – Size

Node	Element/ Attribute	Required	Description	Pattern
NARRTYPE	A	Y	Narrative type i.e. Set to '142'	
NARRDESC	E	N	Description of narrative i.e. Set to 'Size'	
TEXT	E	N	Narrative text	

### 3.8.9.8 ORDERLINE-NARRATIVE

Using for Ticketing: 144 – Season

Node	Element/ Attribute	Required	Description	Pattern
NARRTYPE	A	Y	Narrative type i.e. Set to '144'	
NARRDESC	E	N	Description of narrative i.e. Set to 'Season'	
TEXT	E	N	Narrative text	

### 3.8.9.9 ORDERLINE-NARRATIVE

Using for Ticketing: 200 – ticket price (nb. Allows for promotional pricing)

Node	Element/ Attribute	Required	Description	Pattern
NARRTYPE	A	Y	Narrative type i.e. Set to '200'	
NARRDESC	E	N	Description of narrative i.e. Set to 'Ticket Price'	
TEXT	E	N	Narrative text	

All prices to be shown in £s & pence to 2 decimal places with a decimal point.

### 3.8.10 ORDERLINE-LINETAX – Order line

Node	Element/ Attribute	Required	Description	Pattern
MIXTAXIND	E	N	Mixed rate VAT / Tax indicator	
TAXCODE	E	Y	VAT / Tax rate code e.g. S i.e. Return 'S' if standard rate (17.5%) or return 'Z' if zero-rated.	
TAXRATE	E	Y	VAT / Tax rate (%) e.g. 17.5	
TAXVALUE	E	Y	Line VAT / Tax value e.g. 260.75	
TAXREF	E	N	Commodity code	
TAXREFDESC	E	N	Commodity code description	

## 3.9 DISCOUNT – Discount Details

Node	Element/ Attribute	Required	Description	Pattern
DISCTYPE	A	Y	Type of discount	
DISCAMOUNT	E	Y	Amount of discount	

### 3.10 NARRATIVE – Common narrative format

Node	Entity/ Attribute	Required	Description	Pattern
NARRATIVE	E	N	See 3.10.1	
NARRATIVE	E	N	See 3.10.2	
NARRATIVE	E	N	See 3.10.3	
NARRATIVE	E	N	See 3.10.4	

#### 3.10.1 NARRATIVE-NARRATIVE

Using for delivery instructions at order level

Node	Entity/ Attribute	Required	Description	Pattern
NARRTYPE	A	Y	Narrative type e.g. SPI	
NARRDESC	E	N	Description of narrative e.g. 'Special Instructions'	
TEXT	E	N	Narrative text e.g. Deliveries will not be accepted ...	

#### 3.10.2 NARRATIVE-NARRATIVE

Using for delivery instructions at order level

Node	Entity/ Attribute	Required	Description	Pattern
NARRTYPE	A	Y	Narrative type i.e. Set to DELIN2	
NARRDESC	E	N	Description of narrative	
TEXT	E	N	Narrative text	

#### 3.10.3 NARRATIVE-NARRATIVE

Using for delivery instructions at order level

Node	Entity/ Attribute	Required	Description	Pattern
NARRTYPE	A	Y	Narrative type i.e. Set to DELIN3	
NARRDESC	E	N	Description of narrative	
TEXT	E	N	Narrative text	

#### 3.10.4 NARRATIVE-NARRATIVE

Using for delivery instructions at order level

Node	Entity/ Attribute	Required	Description	Pattern
NARRTYPE	A	Y	Narrative type i.e. Set to DELIN4	
NARRDESC	E	N	Description of narrative	
TEXT	E	N	Narrative text	

### 3.11 ORDERTOTAL – Order totals

Node	Entity/ Attribute	Required	Description	Pattern
ORDNOLINES	E	Y	Number of order lines e.g. 1	
TOTALINES	E	Y	Hash total of line quantities e.g.1	

XML Purchase Orders

<b>Node</b>	<b>Entity/ Attribute</b>	<b>Required</b>	<b>Description</b>	<b>Pattern</b>
ORDLINETOT	E	Y	Total line goods value e.g. 1490	
ORDFREIGHT	E	N	Freight charges e.g. 0	
ORDTAXTOT	E	Y	VAT / tax value e.g. 260.75	
ORDGROSSPAY	E	Y	Gross value e.g. 1750.75	

All prices to be shown in £s & pence to 2 decimal places with a decimal point.

## 4. XML PURCHASE ORDERS

### 4.1 File Name Conventions

The file naming conventions for XML Purchase Orders is a 7 digit number followed by .xml.

nnnnnnn.xml

e.g. 1734548.xml

### 4.2 XML Declaration

The XML declaration, which is at the top of the file before the ORDER tag, contains the encoding of the document. This encoding defines the character set used by the document, which in this case is the Windows character set 1252.

### 4.3 Namespace

The namespace is declared within the ORDER tag. The namespace for XML Purchase Orders is: urn:www-basda-org/schema/purord.xml

### 4.4 Sample of XML Purchase Orders File

```
<?xml version="1.0" encoding="Windows-1252" ?>
- <ORDER xmlns="urn:www-basda-org/schema/purord.xml">
  - <ORDERHEAD ORDERTYPE="PUO" FUNCCODE="FIO">
    <ORDERDESC>Purchase Order</ORDERDESC>
    <FUNCDESC>Firm Order</FUNCDESC>
  - <CURRENCY CURRTYPE="ORD" CURRCODE="GBP">
    <CURRTYPEDESC>Order Currency</CURRTYPEDESC>
    <CURRCODEESC>Pound Sterling</CURRCODEESC>
  </CURRENCY>
  </ORDERHEAD>
  - <REFERENCE REFTYPE="CUR">
    <REFDESC>Customers Purchase Order Number</REFDESC>
    <REFCODE>124301</REFCODE>
    <REFVALUE>CSM</REFVALUE>
    <REFDEPT>0974</REFDEPT>
  </REFERENCE>
  - <DATEINFO DATETYPE="ORD">
    <DATEDESC>Purchase Order Date</DATEDESC>
    <DATE>2002-02-19</DATE>
  </DATEINFO>
  - <DATEINFO DATETYPE="EDD">
    <DATEDESC>Earliest Delivery Date</DATEDESC>
    <DATE>2002-02-19</DATE>
  </DATEINFO>
  - <DATEINFO DATETYPE="LDD">
    <DATEDESC>Latest Delivery date</DATEDESC>
```

```

    <DATE>2002-02-19</DATE>
  </DATEINFO>
- <SUPPLIER>
  - <PARTYCODE IDTYPE="BCS">
    <IDDESC>Buyers Code for Supplier</IDDESC>
    <IDCODE>5029839</IDCODE>
  </PARTYCODE>
  - <ADDRESS>
    <NAME>TEST SUPPLIER</NAME>
    <STREET> FARADAY ROAD </STREET>
    <CITY> SWINDON </CITY>
    <STATE>WILTSHIRE</STATE>
    <POSTCODE>SN3 3HS</POSTCODE>
    <COUNTRY>England</COUNTRY>
  </ADDRESS>
  - <CONTACT CONTACTYPE="">
    - <COMMNUMB CONUMTYPE="">
      <CONTACTNO />
    </COMMNUMB>
  </CONTACT>
</SUPPLIER>
- <BUYER>
  - <PARTYCODE IDTYPE="SCB">
    <IDDESC>Suppliers Code for Buyer</IDDESC>
    <IDCODE>5019589000016</IDCODE>
  </PARTYCODE>
  - <ADDRESS>
    <NAME>KENDALS</NAME>
    <STREET>PO BOX 60, DEANSGATE</STREET>
    <CITY>MANCHESTER</CITY>
    <STATE>LANCASHIRE</STATE>
    <POSTCODE>M60 3AU</POSTCODE>
    <COUNTRY>England</COUNTRY>
  </ADDRESS>
  - <CONTACT CONTACTYPE="">
    - <COMMNUMB CONUMTYPE="">
      <CONTACTNO />
    </COMMNUMB>
  </CONTACT>
</BUYER>
- <DELIVERY>
  - <PARTYCODE IDTYPE="DEL">
    <IDDESC>Deliver To</IDDESC>
    <IDCODE>1612</IDCODE>
  </PARTYCODE>
  - <ADDRESS>
    <NAME>MRS K SCOTT</NAME>
    <STREET> MOSS HALL ROAD </STREET>
    <CITY>BURY</CITY>
    <STATE>LANCASHIRE</STATE>
    <POSTCODE>BL9 7JJ</POSTCODE>
    <COUNTRY>England</COUNTRY>

```



```

    </ADDRESS>
  - <CONTACT CONTACTYPE="">
    - <COMMNUMB CONUMTYPE="">
      <CONTACTNO />
    </COMMNUMB>
  </CONTACT>
  - <CARRIER>
    - <PARTYCODE IDTYPE="">
      <IDCODE />
    </PARTYCODE>
    <REFERENCE REFTYPE="" />
    <ADDRESS />
    - <QUANTITY>
      <QUANTITYAMOUNT />
    </QUANTITY>
    - <NARRATIVE NARRTYPE="">
      <TEXT />
    </NARRATIVE>
  </CARRIER>
</DELIVERY>
- <INVOICETO>
  - <PARTYCODE IDTYPE="INV">
    <IDDESC>Invoice To</IDDESC>
    <IDCODE>5019589000016</IDCODE>
  </PARTYCODE>
  <ADDRESS />
  - <CONTACT CONTACTYPE="">
    - <COMMNUMB CONUMTYPE="">
      <CONTACTNO />
    </COMMNUMB>
  </CONTACT>
</INVOICETO>
- <ORDERLINE LINETYPE="GDS" LINEACTION="1">
  <LINETYPEDESC>Goods</LINETYPEDESC>
  <LINEACTIONDESC>Add Line</LINEACTIONDESC>
  <LINENO>1</LINENO>
  <LINETOTAL>535.00</LINETOTAL>
  - <PRODUCT PRODCODETYPE="SPC">
    <PRODCODEDESC>Sellers Product Code</PRODCODEDESC>
    <PRODNUM>CHIC1</PRODNUM>
    <DESCRIPTION>CHICAGO 2 SEATER</DESCRIPTION>
  </PRODUCT>
  - <PRODUCT PRODCODETYPE="BPC">
    <PRODCODEDESC>Buyers Part</PRODCODEDESC>
    <PRODNUM>504555913</PRODNUM>
    <DESCRIPTION>CHICAGO 2 SEATER</DESCRIPTION>
  </PRODUCT>
  - <PRODUCT PRODCODETYPE="ANA">
    <PRODCODEDESC>Sellers EAN13</PRODCODEDESC>
    <PRODNUM>CHIG2</PRODNUM>
    <DESCRIPTION>CHICAGO 2 SEATER</DESCRIPTION>

```

```

</PRODUCT>
- <PRODUCT PRODCODETYPE="USR">
  <PRODCODEDESC>HOFEAN13</PRODCODEDESC>
  <PRODNUM>2105045559130</PRODNUM>
  <DESCRIPTION>CHICAGO 2 SEATER</DESCRIPTION>
</PRODUCT>
- <QUANTITY QTYCODE="ORD" QTYUOM="PCE">
  <QTYCODESC>Ordered Quantity</QTYCODESC>
  <QUANTITYAMOUNT>1</QUANTITYAMOUNT>
  <QTYUOMDESC>Pieces</QTYUOMDESC>
  <PACKSIZE>1</PACKSIZE>
</QUANTITY>
- <PRICE PRICETYPE="COS" PRICEUOM="PCE">
  <PRICEDESC>Cost</PRICEDESC>
  <PRICEAMOUNT>535.00</PRICEAMOUNT>
  <PRICEUOMDESC>Piece</PRICEUOMDESC>
</PRICE>
- <PRICE PRICETYPE="RRP" PRICEUOM="PCE">
  <PRICEDESC>Selling</PRICEDESC>
  <PRICEAMOUNT>999.00</PRICEAMOUNT>
  <PRICEUOMDESC>Piece</PRICEUOMDESC>
</PRICE>
<DISCOUNT DISCTYPE="" />
- <DATEINFO DATETYPE="">
  <DATE>2005-05-19</DATE>
</DATEINFO>
- <DIMENSION DIMTYPE="">
  <DIMVALUE />
</DIMENSION>
- <REFERENCE REFTYPE="ART">
  <REFVALUE>504555913</REFVALUE>
</REFERENCE>
- <DELIVSCHED>
  - <QUANTITY QTYCODE="">
    <QUANTITYAMOUNT />
  </QUANTITY>
  - <DATEINFO DATETYPE="DED">
    <DATE>2004-07-09</DATE>
  </DATEINFO>
  - <DELIVERY>
    - <PARTYCODE IDTYPE="">
      <IDCODE />
    </PARTYCODE>
    <ADDRESS />
    - <CONTACT CONTACTTYPE="">
      - <COMMNUMB CONUMTYPE="">
        <CONTACTNO />
      </COMMNUMB>
    </CONTACT>
    - <CARRIER>
      - <PARTYCODE IDTYPE="">

```

```

        <IDCODE />
      </PARTYCODE>
      <REFERENCE REFTYPE="" />
      <ADDRESS />
      - <QUANTITY QTYCODE="">
        <QUANTITYAMOUNT />
      </QUANTITY>
      - <NARRATIVE NARRTYPE="">
        <TEXT />
      </NARRATIVE>
    </CARRIER>
  </DELIVERY>
  - <NARRATIVE NARRTYPE="">
    <TEXT />
  </NARRATIVE>
</DELIVSCHED>
- <NARRATIVE NARRTYPE="GNAR1">
  <TEXT>ALF 825582</TEXT>
</NARRATIVE>
- <NARRATIVE NARRTYPE="GNAR2">
  <TEXT />
</NARRATIVE>
- <NARRATIVE NARRTYPE="GNAR3">
  <TEXT />
</NARRATIVE>
- <NARRATIVE NARRTYPE="GNAR4">
  <TEXT />
</NARRATIVE>
- <NARRATIVE NARRTYPE="249">
  <NARRDESC>Ticket Type</NARRDESC>
  <TEXT />
</NARRATIVE>
- <NARRATIVE NARRTYPE="141">
  <NARRDESC>Colour</NARRDESC>
  <TEXT />
</NARRATIVE>
- <NARRATIVE NARRTYPE="142">
  <NARRDESC>Size</NARRDESC>
  <TEXT />
</NARRATIVE>
- <NARRATIVE NARRTYPE="144">
  <NARRDESC>Season</NARRDESC>
  <TEXT />
</NARRATIVE>
- <NARRATIVE NARRTYPE="200">
  <NARRDESC>Ticket Price</NARRDESC>
  <TEXT>999.00</TEXT>
</NARRATIVE>
- <LINETAX>
  <TAXCODE>S</TAXCODE>
  <TAXRATE>17.5</TAXRATE>

```

```
        <TAXVALUE>93.63</TAXVALUE>
    </LINETAX>
</ORDERLINE>
- <DISCOUNT DISCTYPE="">
    <DISCAMOUNT>0</DISCAMOUNT>
</DISCOUNT>
- <NARRATIVE NARRTYPE="SPI">
    <TEXT />
</NARRATIVE>
- <NARRATIVE NARRTYPE="DELIN1">
    <TEXT />
</NARRATIVE>
- <NARRATIVE NARRTYPE="DELIN2">
    <TEXT />
</NARRATIVE>
- <NARRATIVE NARRTYPE="DELIN3">
    <TEXT />
</NARRATIVE>
- <NARRATIVE NARRTYPE="DELIN4">
    <TEXT />
</NARRATIVE>
- <ORDERTOTAL>
    <ORDNOLINES>1</ORDNOLINES>
    <TOTALINES>1</TOTALINES>
    <ORDLINETOT>1490.00</ORDLINETOT>
    <ORDTAXTOT>260.75</ORDTAXTOT>
    <ORDGROSSPAY>1750.75</ORDGROSSPAY>
</ORDERTOTAL>
</ORDER>
```